

CD Pre²⁴

COMBINATION CD PLAYER AND DIGITAL / ANALOGUE PRE-AMPLIFIER

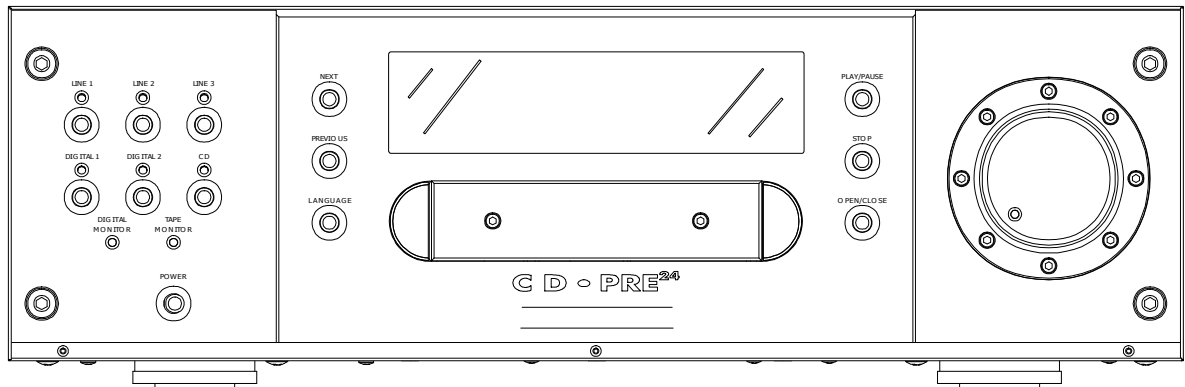

INSTRUCTIONS FOR USE

*Thank you for purchasing the Musical Fidelity CD Pre²⁴.
Used properly and carefully, it should give many years of outstanding
musical reproduction.*

*The CD Pre²⁴ uses the latest 24 Bit DAC technology and jitter reduction
techniques to achieve both an excellent technical specification and
unparalleled sound quality.*

*Æsthetically, the CD Pre²⁴ is a perfect match for the
A3.2 FM tuner and A3.2 amplifier.
Together these components form one of the finest hi-fi systems available.*

*Dust regularly with a soft duster or soft brush but be careful when using
cleaning or polishing agents - they may harm the surface finish.*

*If you have any questions about your audio system,
please consult your dealer who is there to help and advise.*



MUSICAL FIDELITY



CONTENTS

PAGE		
3	Safety Information:	- Mains plug (U.K. only) - Modification warning
4	Safety Information: (continued)	- Warnings
5	User Information:	- Radio-frequency interference
6	General Advice:	- Installation precautions - User information
7	Remote Control:	- Use and illustration
8	Facilities and Connections:	- Front and rear panel illustrations
9	Interconnection and Pre-amp operation:	- Interconnection procedure - Switching on - Input source selection
10	Pre-amplifier, Operation:	- Mute function - Line input monitoring - Tape recording
11	CD Player, Basic Operation:	- Loading and playing discs - Pause - Index points
12	CD Player, Basic Operation:	- Track selection - Search - Displaying playback time
13	CD Player, Special Features:	- Repeat playback - A-B repeat playback - Shuffle playback
14	CD Player, Special Features:	- Introduction search - Programmed play - Random Music Selection
15	CD Player, Special Features:	- Programmed play - continued - Autospace - Display on / off
16	CD Text:	- CD text discs
17	CD Text:	- Other languages
18	Troubleshooting:	- Basic problem solving
19	Specifications	

SAFETY INFORMATION

IMPORTANT! (U.K. only)

This unit is supplied in the U.K. with a mains lead fitted with a moulded 13 amp plug. If, for any reason, you need to cut off the plug, please remove the fuse holder and dispose of the plug safely, out of reach of children. ***It must not be plugged into a mains outlet.***

The wires in the mains lead supplied with this appliance are coloured in accordance with the following code:

Green and yellow.....Earth
Blue.....Neutral
Brown.....Live

WARNING - This appliance must be earthed

As the colours of the wires of the mains lead of this appliance may not correspond with the coloured markings identifying the terminals in your plug, proceed as follows:

The wire which is coloured green-and-yellow must be connected to the terminal in the plug which is marked with the letter E or coloured green or green-and-yellow, or by the earth symbol:



The wire which is coloured brown must be connected to the terminal which is marked with the letter L or coloured red.

The wire which is coloured blue must be connected to the terminal which is marked with the letter N or coloured black.

If connecting to a BS1363 plug, a 13 amp fuse must be used.

WARNING:

ANY MODIFICATIONS TO THIS PRODUCT NOT EXPRESSLY APPROVED BY MUSICAL FIDELITY WHO IS THE PARTY RESPONSIBLE FOR STANDARDS COMPLIANCE COULD VOID THE USER'S AUTHORITY TO OPERATE THIS EQUIPMENT.

WARNINGS

CLASS 1 LASER PRODUCT

This CD player has been designed and manufactured according to FDA regulations "title 21, CFR, chapter 1, subchapter J, based on the Radiation Control for Health and Safety Act of 1968", and is classified as a Class 1 laser product. There is no hazardous radiation during normal use because invisible radiation emitted inside this product is completely confined within the protective housing. However you must observe the following important warnings:

CAUTION !

- **THIS CD PLAYER USES INVISIBLE LASER LIGHT. WHEN THE PLAYER OPERATES, LASER LIGHT IS RADIATED INTERNALLY. DO NOT REMOVE THE PROTECTIVE HOUSINGS.**
- **USE OF CONTROLS OR ADJUSTMENTS OR PERFORMANCE OF PROCEDURES OTHER THAN THOSE SPECIFIED HEREIN MAY RESULT IN HAZARDOUS RADIATION EXPOSURE CAUSING EYE INJURY.**
- **IF THIS PRODUCT DEVELOPS A FAULT, PLEASE CONTACT YOUR AUTHORISED MUSICAL FIDELITY SERVICE AGENT. DO NOT ATTEMPT TO SERVICE IT YOURSELF AND DO NOT CONTINUE TO USE THIS PRODUCT IN A FAULTY STATE.**

WARNING AND INFORMATION LABELS:

THIS PRODUCT COMPLIES WITH DHHS RULES 21 CFR, CHAPTER 1, SUBCHAPTER J, PART 1040 AT DATE OF MANUFACTURE. THIS PRODUCT COMPLIES WITH PART 15 OF THE FCC RULES. OPERATION IS SUBJECT TO TWO CONDITIONS:

- 1 THIS DEVICE MAY NOT CAUSE HARMFUL INTERFERENCE, AND
- 2 THIS DEVICE MUST ACCEPT ANY INTERFERENCE RECEIVED, INCLUDING INTERFERENCE THAT MAY CAUSE UNDESIRED OPERATION.

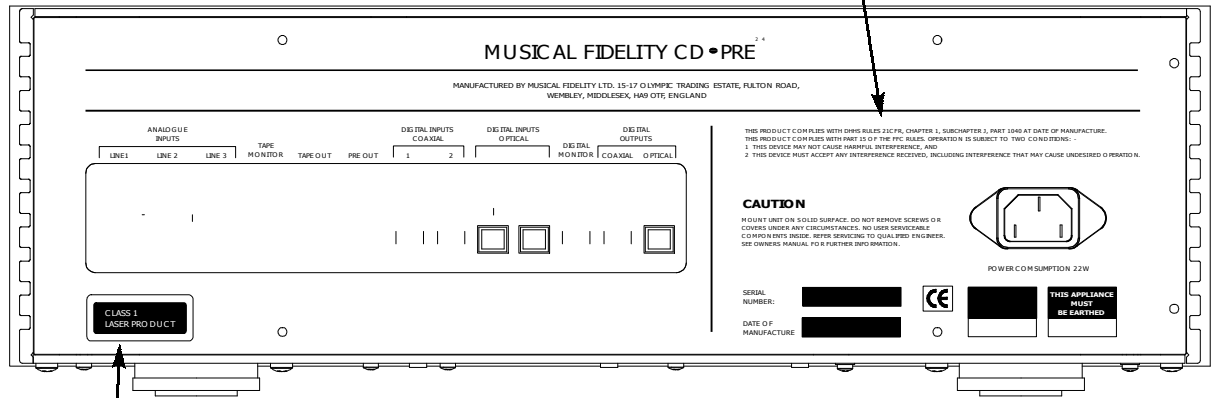

MUSICAL FIDELITY CD • PRE 24

MANUFACTURED BY MUSICAL FIDELITY LTD. 15-17 OLYMPIC TRADING ESTATE, FULTON ROAD, WEMBLEY, MIDDLESEX, HA9 0TE, ENGLAND

ANALOGUE INPUTS: LINE 1, LINE 2, LINE 3, TAPE MONITOR, TAKE-OUT, PRE-OUT

DIGITAL INPUTS: COAXIAL, OPTICAL

DIGITAL MONITOR, DIGITAL OUTPUTS: COAXIAL, OPTICAL

CLASS 1 LASER PRODUCT

CAUTION

DO NOT REMOVE SCREWS OR COVERS UNDER ANY CIRCUMSTANCES. NO USER SERVICEABLE COMPONENTS INSIDE. REFER SERVICING TO QUALIFIED ENGINEER. SEE OWNER'S MANUAL FOR FURTHER INFORMATION.

POWER CONSUMPTION 22W

SERIAL NUMBER: [REDACTED]

DATE OF MANUFACTURE: [REDACTED]

CE

THIS APPLIANCE MUST BE EARTHED

**CLASS 1
LASER PRODUCT**

FITTED INTERNALLY
TO BASE OF CHASSIS

CAUTION -	INVISIBLE LASER RADIATION WHEN OPEN AND INTERLOCKS DEFEATED. AVOID EXPOSURE TO BEAM.
VORSICHT! -	UNSICHTBARE LASERSTRAHLUNG TRITT AUS, WENN DECKEL GEÖFFNET UND WENN SICHERHEITSVERRIEGELUNG ÜBERBRÜCKT IST NICHT DEM STRAHL AUSSETZEN!
VARNING -	SYNLIG LASERSTRÅLNING NÄR DENNA DEL ÄR ÖPPNAD OCH SPÄRR ÄR URKOPPLAD. STRÅLEN ÄR FARLIG.
ADVARSEL -	USYNLIG LASERSTRÅLING VED ÅBNING. NAR SIKKERHEDSAFBRYDERE ER UDE AF FUNKTION. UNNGA UDSÆTTELSE FOR STRÅLING.
VAROITUS! -	SUOJAKOTELOA EI SAA AVATA. LAITE SISÄLTÄÄ LASERDIODIN, JOKA LÄHETTÄÄ (NÄKYMÄTONTÄ) SILMILLE VAARALLISTA LASERSÄTEILYÄ.

RADIO - FREQUENCY INTERFERENCE (RFI)

This equipment uses and can radiate radio frequency energy, and if not installed and operated in accordance with the instructions, may cause interference to radio communications and other electronic equipment.

However, it is designed to minimise RFI, and accordingly been tested to North American standards (FCC regulations - limits for a class B digital device pursuant to part 15 of the rules). These requirements are intended to provide reasonable protection against excessive interference in a residential installation.

Conversely, the product has also been checked to ensure that its own operation is not adversely affected by normal background levels of RFI received externally.

However, if interference is experienced, for instance to radio or TV broadcasts, the user is recommended to try one or more of the following measures:

- Identify the source of interference by turning off power to the CD Pre or other equipment individually, and checking whether the problem then disappears.
- Re-orientate or relocate the receiving aerial.
- Move the CD Pre²⁴ away from the receiver.
- Connect the CD Pre²⁴ to a mains outlet on a different circuit from the receiver.
- Consult a dealer or experienced TV/radio technician for help.

If a problem persists, please contact Musical Fidelity's service department.

GENERAL ADVICE

INSTALLATION PRECAUTIONS AND USER INFORMATION

Your CD Pre²⁴ is designed and built to provide trouble-free performance, but as with all electronic devices it is necessary to observe a few precautions:

- * Note all warnings shown on the back of the unit.
- * Only connect the CD Pre²⁴ to a mains outlet having the same voltage as marked on the back of the unit.
- * Always switch off the mains supply before connecting or disconnecting your audio equipment.
- * Position the mains lead and signal interconnects where they are not likely to be walked on or trapped by items placed on them.
- * Do not use near water, or place water-filled containers on the pre-amplifier, for example flower vases or potted plants. *If water does spill into the equipment, immediately pull out the mains plug from the wall socket and inform your dealer, who should then check the unit before further use. Entry of liquid into the pre-amplifier is dangerous, and may cause electric shock or fire hazard.*
- * Do not place the unit near heat sources such as radiators, direct sunlight or above other equipment which becomes warm with use. Do not obstruct ventilation slots.
- * Do not remove any covers or try to gain access - refer all service work to an authorised Musical Fidelity agent. There are no internal user adjustments.
NOTE: Unauthorised opening of the equipment will invalidate any warranty claims.
- * There are fuses inside this product. In the unlikely event that one blows, refer the unit to your audio dealer.
Do **NOT** try to replace the fuse yourself as this will invalidate the warranty.
- * Dust regularly with a soft duster or soft brush. For more thorough cleaning of the cabinet and remote control, use a moist cloth. We do not recommend the use of solvents such as white spirit or thinners, as they could damage the surface finish.
- * The electronics in modern hi-fi equipment is complex and may, therefore, be adversely affected or damaged by lightning. For protection of your audio system during electrical storms, remove the mains plugs and disconnect any aerial lead.
- * If after-sales service is required, to help your dealer identify the CD Pre²⁴, please quote the serial number located on the rear panel of the unit.

REMOTE CONTROL

REMOTE CONTROL

The remote control enables most functions of the CD pre-amplifier to be operated from a convenient distance.

Equivalent buttons on the remote handset have the same functions as the those on the front panel of the unit.

Some operations are only available via the handset.

As the remote control uses an invisible infra-red light beam, the transmitter must be pointed directly towards the receiver window on the front of the pre-amplifier, without visual obstruction between them.

If the range of the remote control greatly decreases, replace the batteries with new ones. Do not mix old and new batteries - four are required, type SUM-4, AAA or LR03.

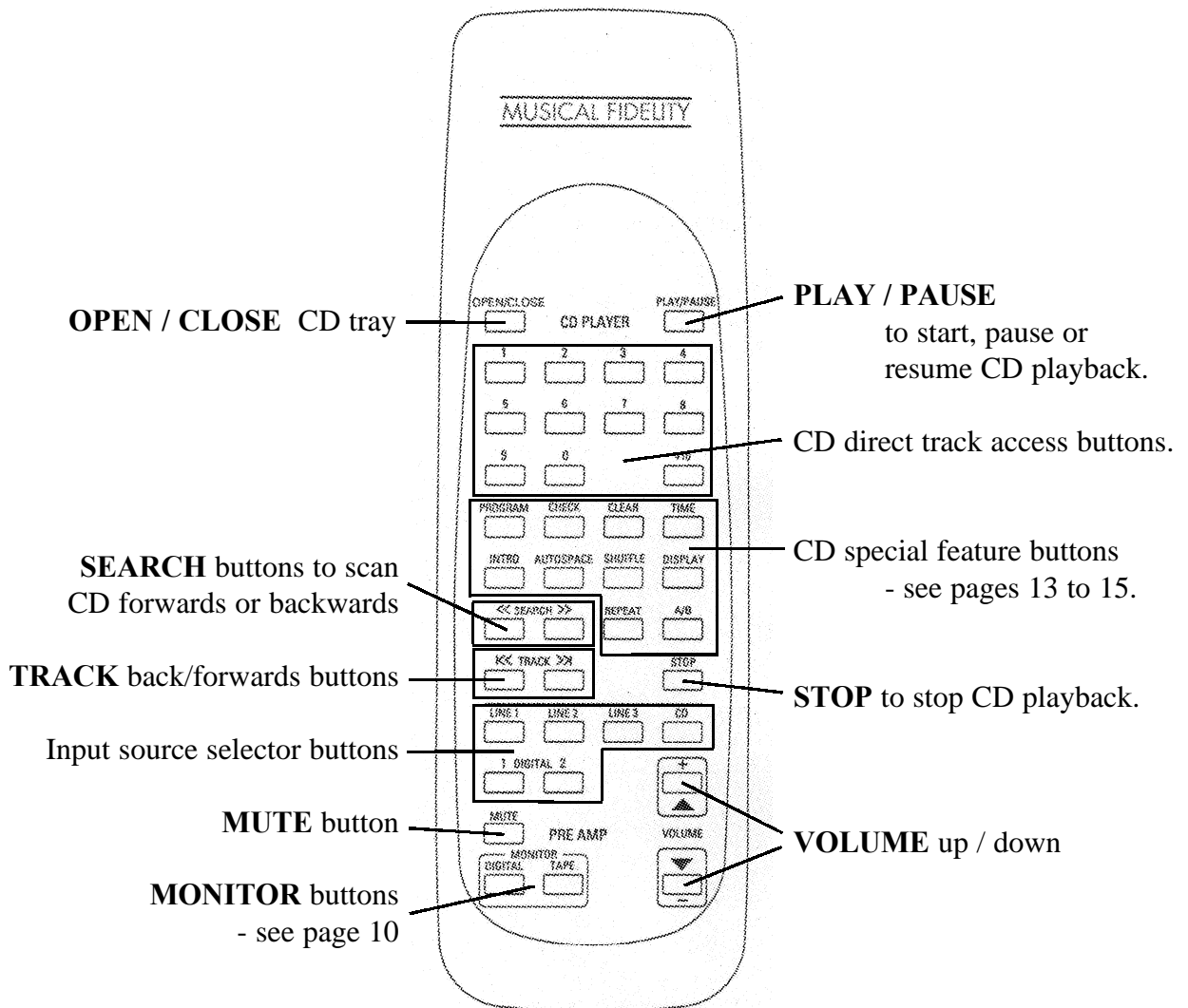

FACILITIES AND CONNECTIONS

FRONT PANEL

- | | | | |
|---|---|---|--|
| 1 | LINE 1 input selector button and LED | 4 | NEXT CD track button |
| 2 | LINE 2 input selector button and LED | 5 | Display (incorporates infra-red remote control receiver) |
| 3 | LINE 3 input selector button and LED | 6 | CD PLAY / PAUSE button |

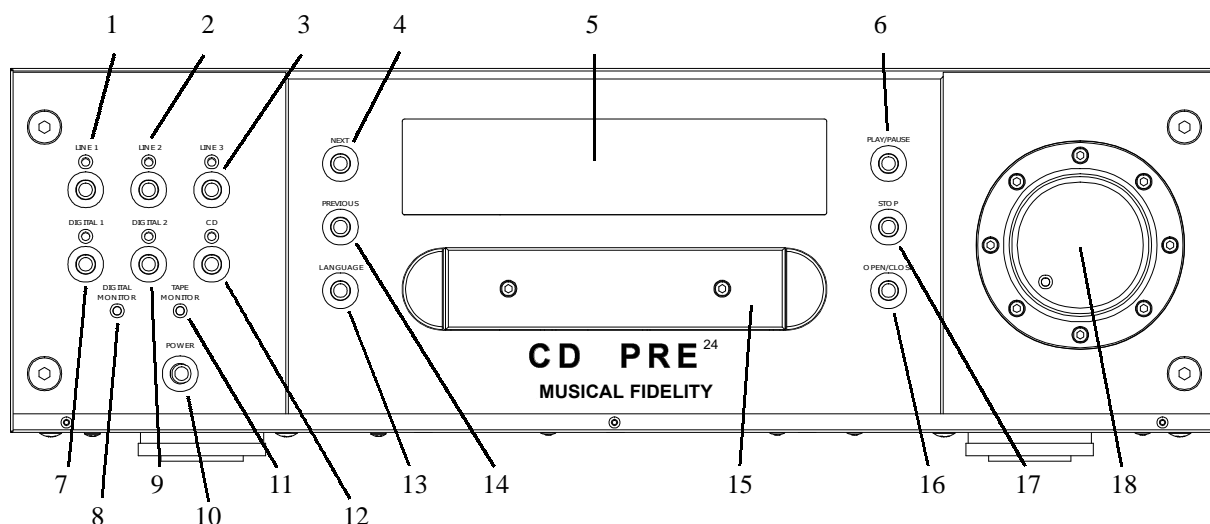

- | | | | |
|----|--|----|---|
| 7 | DIGITAL 1 input selector button and LED | 13 | CD LANGUAGE button (see page 17) |
| 8 | Digital monitor LED (see page 10) | 14 | PREVIOUS CD track button |
| 9 | DIGITAL 2 input selector button and LED | 15 | CD drawer |
| 10 | POWER mains on/off switch | 16 | CD drawer OPEN / CLOSE button |
| 11 | Tape monitor LED (see page 10) | 17 | CD STOP button |
| 12 | CD input selector button and LED | 18 | Volume control knob with LED |

REAR PANEL

- | | | | | | |
|----|--|----|---|----|--|
| 19 | LINE INPUT 1 - analogue
- left and right | 23 | TAPE OUTPUT - analogue
- left and right (see page 10) | 27 | INPUT 1 - optical |
| 20 | LINE INPUT 2 - analogue
- left and right | 24 | LINE OUTPUT - analogue
left and right (to amplifier) | 28 | INPUT 2 - optical |
| 21 | LINE INPUT 3 - analogue
- left and right | 25 | INPUT 1 - digital co-axial | 29 | DIGITAL MONITOR
- digital co-axial |
| 22 | TAPE MONITOR
- analogue, left and right | 26 | INPUT 2 - digital co-axial | 30 | LINE OUTPUT
- digital co-axial |
| | | | | 31 | LINE OUTPUT
- optical |

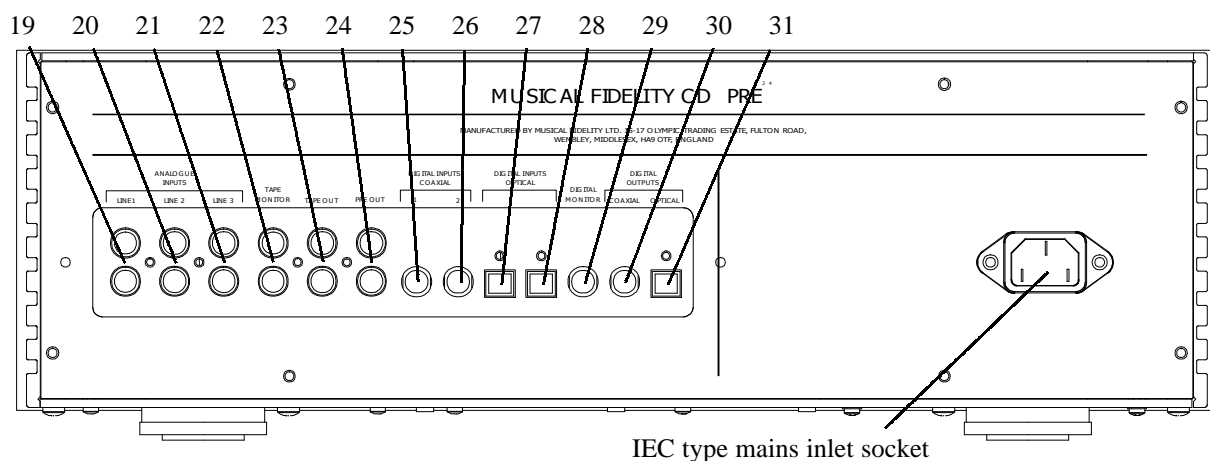

CONNECTIONS & PRE-AMPLIFIER OPERATION

BEFORE CONNECTING

Ensure that mains power to the various components of your audio system is switched off. Please note that audio connecting leads are not supplied with this product.

OUTPUT CONNECTION

The CD Pre²⁴ should be connected to an analogue amplifier input by audio cables with RCA/phono type plugs. These link the left and right PRE OUT sockets on the rear panel of the CD Pre to corresponding line input sockets on the amplifier. Do not use any sockets on the amplifier intended for “vinyl” phono cartridge input, as the sensitive circuit will overload, producing a severely distorted sound.

Alternatively, the DIGITAL OUTPUTS (coaxial or optical) can be used for connection to suitable digital equipment.

All three types of output can be used for feeding different equipment at the same time, if required.

Note that the volume control only affects analogue audio line output to the amplifier, not digital or tape outputs.

INPUT CONNECTION

Analogue inputs are provided for three analogue line sources, and two digital (optical or co-axial).

Do not connect both co-axial and optical leads to the same input.

Connect digital or optical input leads from the other audio sources in your system as required.

The internal D-to-A convertor will also handle digital data from an external CD or DVD audio source.

MAINS POWER CONNECTION

Insert the accessory IEC mains lead plug into the rear panel socket, and then the other end into a convenient wall outlet.

SWITCHING ON

Before applying mains power to other audio components, check that the volume control setting on the CD Pre²⁴ is low (knob turned anticlockwise).

Press the power switch, and the front panel display will light to confirm that the unit is ready for use.

INPUT SOURCE SELECTION

Choose the required input source either by pressing the front panel function buttons or corresponding buttons on the remote control marked LINE 1, 2 or 3, or DIGITAL 1 or 2.

The appropriate front panel LED will then light to confirm your selection.

In the case of digital inputs, if no digital data is being received at the selected input socket, the associated LED will flash instead of remaining constant.

Turn the volume control to obtain the preferred level of sound.

PRE-AMPLIFIER OPERATION

MUTE (*Remote Control Only*)

Pressing the **MUTE** button once on the remote control will interrupt analogue output to the amplifier. Pressing **MUTE** again will restore audio output. The LED in the volume control knob then goes off to indicate that the outputs are muted.

This function does not affect tape monitor or digital outputs.

If the CD Pre²⁴ is powered off while still muted, the effect will be cancelled when next switched on.

DIGITAL MONITORING (*Remote Control Only*)

Any selected input source can be monitored with suitable external equipment from the digital co-axial and/or optical output sockets.

A digital input source (co-axial only) can be monitored by pressing **DIGITAL MONITOR** on the remote control. This does not affect the selected input source, which will still be available from the tape or digital outputs.

This feature may be used together with a digital output to connect to a computer sound card or CD recorder, providing it has digital inputs and outputs.

If the selected input source is digital (CD or DVD audio formats only) a converted analogue signal will also be available at the tape output sockets.

Note that with this arrangement the CD Pre's volume control has no effect.

TAPE MONITOR (*Remote Control Only*)

The CD Pre²⁴ can be used in analogue mode for off-tape monitoring from 3-head tape decks.

This allows the user to compare the original sound with the recorded version while the recording is being made.

In this case, the recorder's left- and right-hand line output sockets should be connected to the CD Pre's tape input, and the recorder's line input sockets to the CD Pre's tape output sockets.

To record, simply select the required source with the appropriate button on the CD Pre's front panel or from the remote control. Pressing **TAPE MONITOR** on the remote control will allow you to monitor what is being recorded, and the matching blue LED on the front panel will light to confirm operation. Press **TAPE MONITOR** again to cancel this mode.

On some 3-head tape decks, there is an additional "tape / source" switch which should be in the "tape" position for this arrangement to function. If in doubt, refer to the recorder's user manual, or consult your dealer.

CD - BASIC OPERATION

LOADING AND PLAYING COMPACT DISCS

If mains power to the CD Pre²⁴ is switched on with a disc already loaded, it will automatically search for the disc and begin playing from the first track. However, playback will not be audible if the input has previously been set to another source before being switched off. The CD button must therefore be pressed first.

If no disc is loaded, after about 3 or 4 seconds the unit will display the following:



To play a disc, press the **OPEN/CLOSE** button to open the transport drawer. When the drawer is fully extended, insert the required disc with the label facing upwards and then press either the **OPEN/CLOSE** or **PLAY/PAUSE** button to close the transport drawer again.

If **OPEN/CLOSE** is pressed, the disc drawer closes and the CD player scans the contents of the disc. After a short delay, the display window then shows for approximately 4 seconds the total number of tracks available on the CD, and total playing time, for example:



Display time **0** on the left then replaces the temporary track and time information, indicating that a disc is loaded but not yet playing.

The "calendar" grid pattern at the right-hand end of the display also confirms tracks available for playing up to the first 20, but remains displayed. In the above example there are 4 tracks on the disc.

DISC PLAY

If **PLAY/PAUSE** is pressed, the CD player will go into play mode, an arrow confirming playback will appear on the left, and the current track and index point will be displayed similar to the following example:



Again, the calendar grid shows playback progress of the first 20 tracks only.

When all tracks on the CD have been played, playback stops and the display reverts to:



PAUSE

Pressing the **PLAY/PAUSE** button whilst a disc is playing pauses playback of the disc. A pause symbol (**||**) appears in the display window next to the play arrow. The disc will continue spinning but the track does not advance and the CD Pre's output is muted.

Pressing **PLAY/PAUSE** again resumes playback from the same place.

INDEX POINTS

Some CDs contain index points within a track to separate a musical piece into different movements. If used, these index point numbers (one or two digits, up to 99) will appear in the display under the INDEX graphic. Otherwise, index number 1 will be displayed.

CD - BASIC OPERATION

STOP

Playback can be stopped at any time by pressing the **STOP** button once.

TRACK SELECTION

To change track, the track skip buttons **NEXT** and **PREVIOUS** can be pressed to jump forwards or backwards one track in either direction. Note that a single press of the **PREVIOUS** button restarts playback at the beginning of the current track. A double-press is needed to jump back to the previous track. Corresponding **TRACK** buttons on the remote control are also marked |<< and >>|. If either button is held down, the CD Pre²⁴ will quickly step through the available tracks in the required direction.

TRACK SELECTION (Remote control)

A specific track can be selected directly by pressing the required track number button on the remote control. The chosen track then plays immediately.

To play a track number with two digits, press the **10+** button on the remote control followed by the first digit, then the second digit. For example, to obtain track 27, press **10+**, then **2**, then **7**.

SEARCH

The **SEARCH** buttons can be used to fast-forward or fast-rewind during playback in a similar way to a video or tape cassette player. This permits location of particular passages at high speed with the audio playback of the CD still active.

Pressing the forward-search button (>>) fast winds forwards whilst the search backwards button (<<) fast winds backwards. As the unit searches through a track, the

track time remaining display (far right digits) will be seen to advance rapidly in the required direction. For both directions the unit will return to normal playback when the button is released.

DISPLAYING PLAYBACK TIME

There are three playback time display modes accessed progressively by pushing the **TIME** button on the remote control. The default mode (e.g. after switch on) shown below indicates the elapsed time for the currently playing track (2 minutes 34 seconds in this example):



Pushing the **TIME** button once changes the display to show the remaining time for the current track (4 minutes 29 seconds in this example):



Pushing the **TIME** button again changes the display to show the remaining time for the whole disc (33 mins 54 secs) below:



(Note: Track and Index displays are not shown in this mode).

A third press of the **TIME** button will now bring the display back to the original (elapsed track time) mode.

REPEAT PLAYBACK

The **REPEAT** button on the remote control allows the repeated playback of either one track or all tracks on the disc.

By pressing the **REPEAT** button once, you can repeat the entire disc (or the programmed selections - see page 14) over and over again. Large letters **REPEAT** briefly replace track, index and time information followed by a smaller, permanent **REPEAT** legend underneath.

If the **REPEAT** button is pressed a second time, only the current track is repeated. Large letters **REPEAT 1** briefly replace track, index and time information followed by a **REPEAT 1** legend underneath.

Pressing **REPEAT** a third time cancels repeat mode. Graphics **REPEAT OFF** then briefly replace track, index and time information before reverting to a normal disc play display.

A-B REPEAT PLAYBACK

“A-B repeat” provides the option of playing just a certain section of the disc over and over again.

Find the beginning of the required section either by listening, or using the display time as a guide. When the desired starting point is reached, press button **A/B** on the remote control. The display will show **REPEAT** and the flashing letter **A**.

When the disc has reached the end of the required section, press the **A-B** button again. Letters **A-B** will now be illuminated in the display, and the unit continuously plays the selected part of the disc.

To cancel A-B repeat mode, press **REPEAT** on the remote control. Graphics **REPEAT OFF** then briefly replace track, index and time information in the display.

SHUFFLE PLAYBACK

The **SHUFFLE** feature allows tracks on the discs to be played in random sequence rather than the normal consecutive order. Tracks are also played in a different order each time the disc is restarted, or another disc loaded.

This function is obtained by pressing **SHUFFLE** on the remote control with the unit either stopped or playing.

If playing, the word **SHUFFLE** in large letters briefly replaces track, index and time display information, before a permanent red indication provides a reminder that the function has been activated.

From stop mode, pressing **PLAY/PAUSE** also begins shuffle play.

If the CD Pre²⁴ is already playing, play will continue until either the current track has finished, or either the track **>>|** button on the remote control or **NEXT** on the unit is pressed. Shuffle play is then further confirmed by the track number display digits briefly changing into segments revolving in a box formation.

If the **SHUFFLE** button is now pressed for a second time, the word **CONTINUE** briefly replaces track, index and time display information. The unit then resumes normal play function, except that it now only plays previously unplayed tracks of the current disc, unless others are then manually selected. Shuffle play is cancelled by pressing the **STOP** button.

INTRODUCTION SEARCH

The introduction-search function allows play back of just the start of each track on the disc, for instance to locate a preferred track by ear.

Press **INTRO** on the remote control, and the display will briefly show:



The first ten seconds (approximately) of each title on the CD are then played (or the first 10 seconds of any programmed titles, see below). The playback arrow in the display window flashes to indicate that this mode is activated.

Track playing time can be changed to approximately 20 or 30 seconds at any time during introduction mode. Press **INTRO** twice or three times in quick succession instead of once, and the revised time will be indicated on the display as:

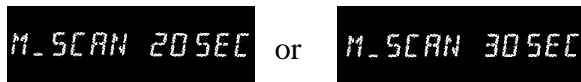

Press **STOP** to cancel introduction mode.

Note: Intro scan time will be memorised as long as the unit is powered on, even when another disc is loaded.

PROGRAMMED PLAY / R.M.S.

The built-in program memory (Random Music Selection function) allows you to store up to 24 tracks and then play them back in the stored order. Each track is stored as a 'STEP' in the program. It is possible to store a track more than once in the same program if required.

Example:- You wish to listen to tracks 14, 7, 9, 9 and 12 in that order on a disc. With the disc loaded and the player stopped, first press **PROGRAM** on the remote control. The word PROGRAM briefly replaces

track, index and time information, before a permanent red display provides a reminder that the function has been activated.

Press the numeric button of the track number corresponding to the first track you wish to store (14 in our example is +10, then 4). That track number will now appear in the display under **TRACK**, number 1 (being the first entry) will appear under **STEP**, and track playing time appears under **MIN SEC**.

Alternatively, the track number can be selected by using the track skip buttons (|<< or >>|).

The calendar grid to the right of the display also confirms this track selection.

Next the second track to be programmed can be selected (7 in our example) either by entering the required number with the numeric buttons or again by using the track skip buttons. As the second track number is selected the step number will be seen to change to a 2 indicating the program step being filled.

If you want to save a track twice in succession (for example 9 followed by 9), then simply press button 9 twice.

Repeat the above procedure by pressing remaining track numbers required (9, 9 again and 12 in our example). Note that as tracks are added, the total playing time indicated increases by a corresponding amount *plus one second per track*. This is to allow access time for the CD mechanism during the program play sequence.

If entry of more than 24 tracks is attempted accidentally, the memory will not accept the extra ones. The following is then briefly displayed:



CD - SPECIAL FEATURES

If at any time you make a mistake or wish to delete a track from the list, press the **CLEAR** button to erase the last step. Repeated pressing of **CLEAR** will then erase each step in reverse order.

If you wish to check the selection before playing back your program, the **CHECK** button can be pressed to step through each track in turn. At the end of the check sequence, the display briefly shows:

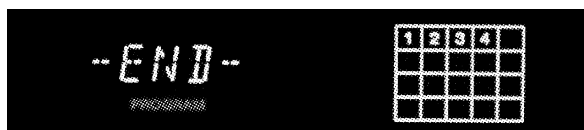

To play the programmed tracks press **PLAY/PAUSE** (or **INTRO** if required, see page 14).

When all programmed tracks have been played, the CD player stops. The same track selection can then be played again by pressing the **PLAY/PAUSE** button.

To cancel this mode, press **PROGRAM**. The word **CONTINUE** then briefly replaces track, index and time display.

Note: The entire program contents will be cleared if you open the disc compartment to load another disc, but this does not cancel program mode itself.

AUTOSPACE

The CD Pre's AUTOSPACE function can be used to insert 4-second silent spaces in between each track as it is played back. This can be useful when making cassette recordings of CDs. Some cassette recorders feature a track skip or search

function which uses the silent gap between tracks to locate each one individually. However, some CDs do not have long enough gaps between tracks for this function to operate properly. AUTOSPACE can solve this problem.

Pressing the **AUTOSPACE** button once activates the function. The legend **AUTOSPACE** will appear in the display. In this mode, once the CD Pre²⁴ has reached the end of a track the **AUTOSPACE** graphic will begin to flash and the elapsed time part of the display will change to count down from four seconds to zero before play of the next track begins.

When zero is reached the **AUTOSPACE** legend stops flashing and play continues at the start of the next track.

Press **AUTOSPACE** again to cancel this mode.

DISPLAY

The CD Pre's display can be switched off with the **DISPLAY** button on the remote control *when a disc is playing*.

However, if the button is pressed without a CD being loaded, or with a disc stopped, track, index and time displays are briefly replaced by the word **DISPLAY OFF** to confirm this mode has been engaged, *but the display remains lit until play is selected*. Pushing the button a second time briefly shows **DISPLAY ON** to confirm that the function has been cancelled.

When in display-off mode, pressing any button will cause the display to return briefly to confirm the new status before again switching off.

CD TEXT DISCS

A small number of CDs released for sale more recently have additional text information contained in the recorded digital data.

The CD Pre²⁴ can individually display either the disc title, artist's name or track title with appropriate control commands.

Only CDs which are identified as having this text feature, either on the disc's label or the library case, will have text function on the CD Pre²⁴.



When a text disc is first loaded, a red CD TEXT legend appears in the display window.

Text is shown on the front display as follows:

When the disc is first loaded:

Initially (1a): Total tracks and total time

TRACK	INDEX	MIN	SEC
4		33.	57
CD TEXT			

then, after a few seconds, (1b):

DISC
(DISC TITLE)
CD TEXT

Then, with each press of the **TIME** button, the display will cycle between the two text states:

2: Main artist's name:

ART.
(MAIN ARTIST)
CD TEXT

1: Return to 1a then 1b,

If a title or name has more than twelve characters, the first 12 only will be displayed after the title or name has finished scrolling.

With disc playing:

Each press of the **TIME** button, the display will cycle between four states:

Original state:

1a: Track title

TRACK
(TRACK TITLE)
CD TEXT

then, after a few seconds:

1b: Track elapsed time:

TRACK	INDEX	MIN	SEC
1	1	23.	45
CD TEXT			

2: Track remaining time:

TRACK	INDEX	MIN	SEC
1		-23.	45
CD TEXT			

3: Disc remaining time:

MIN	SEC
-34.	56
CD TEXT	

4: Track title: (original play mode)

Other Languages:

A limited number of CD text discs also have an “other-language” option.

In this case, after loading the disc, the display shows the current or default language after **MULTI** has been appeared underneath the **TEXT** legend.

If the player cannot read one of the languages identified in the disc’s digital data, the display will show “(OTHER LANG)” after loading the text CD.

To change language with a suitable text disc, before playing the text CD:

Press the **LANGUAGE** button on the front panel. The current operating language will then appear in the display.

Press **NEXT** or **PREVIOUS** on the front panel, or |<< or >>| on the remote control to find the required language.

Press the **LANGUAGE** button again to store the setting.

Notes:

* If a non-text disc is loaded, pressing the **LANGUAGE** button has no effect.

* If a text disc which does not have other languages available *is loaded but not playing*, when the **LANGUAGE** button is pressed “CAN’T SELECT” is displayed

* If the **LANGUAGE** button is pressed *while playing* a multi-language text disc, the current language is displayed momentarily.

TROUBLESHOOTING

Basic problem-solving with the CD Pre²⁴ is similar to troubleshooting other electrical or electronic equipment. Always check the most obvious possible causes first, such as the following examples:

<i>Problem</i>	<i>Possible Cause</i>	<i>Remedy</i>
No power when POWER button is pressed	Power plug is not inserted fully into rear socket	Plug in securely.
No sound	TAPE MONITOR button has been pressed MUTE button has been pressed Wrong input selected	Press TAPE MONITOR button again to cancel. Press MUTE button again to cancel. Select correct input.
Sound is severely distorted, and the volume control needs to be turned down very low	Line output lead is connected to phono pickup input sockets of the amplifier	Re-connect lead to auxilliary sockets or other "line level" amplifier input.
No playback when CD is loaded, and "NO DISC" displayed	Disc has been loaded with the label side down	Re-load with label side up.
Mistracking (sound jumping)	Player receiving vibration or shock Disc is dirty	Change position of player away from speakers. Clean disc surface
Remote control does not work	POWER switch is off One or more batteries inserted the wrong way round Batteries are flat Remote control is not pointed directly towards the front panel of the pre-amplifier	Set switch to on. Insert batteries correctly. Change batteries - do not mix old and new ones. Ensure there is no obstruction between the remote control and front panel.
Remote control range has greatly reduced	Batteries are running out	Change batteries - do not mix old and new ones.

If none of the above actions effect a cure, please contact your dealer or Musical Fidelity service agent. Do not open the case of the CD Pre²⁴ yourself, as this will invalidate the guarantee.

CD Pre²⁴

Combination CD player / digital & analogue pre-amplifier

CD SECTION:

DAC architecture	24 bit Delta-Sigma (Bitstream) Dual differential 8 times oversampling (CD or DVD-audio conversion only)	
Frequency response	20Hz to 20kHz:	< 0.02dB
Channel balance	20Hz to 20kHz:	< 0.02dB
Stereo separation	20Hz to 20kHz:	> 98dB
Total harmonic distortion at 1kHz:	0dB digital level:	0.002%
	-10dB digital level:	0.004%
	-70dB digital level:	0.050%
Signal / noise ratio	20Hz to 20kHz:	114dB A-weighted
Audio output at digital 0dB level, 1kHz:	2.14VRMS nominal	
Total correlated jitter:	< 189pS	

PRE-AMPLIFIER SECTION:

		Direct Analogue	A to D / D to A *
Maximum output for 2.2 Volts RMS input:		8.4VRMS	8.2VRMS
Distortion	20Hz to 20kHz:	< 0.002%	< 0.004%
Frequency response	20Hz to 20kHz:	+ 0, - 0.02dB	+ 0, - 0.37dB
Crosstalk, typical:		85dB	90dB
Channel balance:	20Hz to 20kHz:	< 0.01dB	< 0.02dB
Signal / noise ratio, "A"-weighted	20Hz to 20kHz:	109dB	104dB
Output impedance		50 Ohms	

* These measurements made by linking the co-axial digital output back to the digital monitor, and using DIGITAL MONITOR function. This is converting an analogue signal to digital and then back to analogue, as when linking to a computer or CD recorder.

Power requirements	100 / 115 / 230V AC 50 / 60Hz (Voltage factory preset for country) 22 Watts
Dimensions (approximate)	440mm, 17.3 inches wide 140mm, 5.5 inches high (including feet) 380mm, 14.9 inches deep (including terminals)
Weight	13.5Kg, 29.7lbs unit only, unboxed 17Kg, 37.4lbs in shipping carton
Standard accessories:	Remote control handset, IEC mains lead, 4 batteries (type SUM-4, AAA, LR03)



Musical Fidelity reserves the right to make improvements which may result in specification or feature changes without notice.